



**INFRA-RED BULB WARMER**  
**Model Series: 6016-C**  
**WITH CARVING STATION**  
**OPERATING INSTRUCTIONS**

**INTRODUCTION**

1. Please read instructions before using this appliance.
2. When using electrical appliances, basic precautions should always be followed to reduce the risk of fire, electric shock and injury.
3. Clean machine thoroughly before and after all uses following cleaning instructions below.

**ELECTRICAL REQUIREMENTS**

Plug warmer into a grounded outlet with correct voltage and sufficient power capacity. Refer to the product label (serial plate) on the warmer for voltage and wattage requirements.

**SAFETY INSTRUCTIONS**

1. **Warning!** All power must be disconnected at power source before any service procedure is performed.
2. This appliance is hot when in use. To avoid burns, do not let bare skin touch hot surfaces. Keep combustible materials, such as drapes and other furnishings, away from appliance.
3. Extreme caution is necessary when any appliance is used by or near children and whenever the appliance is left unattended.
4. Always unplug appliance when not in use and before cleaning, adjusting or maintaining this machine. To disconnect appliance, turn controls off and remove plug from power source.
5. Do not operate any appliance with a damaged cord or plug, after the appliance malfunctions, has been dropped, or damaged. Return appliance to an authorized service facility for examination, electrical or mechanical adjustment, or repair.
6. Do not use outdoors. This appliance is not intended for use in wet or moist locations. Never locate appliance where it may fall into water.
7. Connect to properly grounded outlets only. Avoid the use of extension cords. Do not run cord under carpeting, runners, or the like. Arrange cord away from traffic area and where it will not be tripped over.
8. This appliance is equipped with a power cord with a three-blade plug. Plug ONLY into a matching three-blade outlet. DO NOT cut off the third blade or attempt to use with a two-blade extension cord.
9. To prevent a possible fire, it is recommended that the unit is placed on a non-combustible surface.
10. This appliance has electrical parts. Do not use it in areas where gasoline, paint, or flammable liquids are used or stored.

**PREPARATION**

1. Condition wood cutting board per CARE INSTRUCTIONS FOR WOOD CUTTING BOARD below.
2. Place carving station in desired location near the power source.
3. Screw bulb into socket and adjust flexible neck.
4. If warmer fails to work properly when first operated call NEMCO customer service at 1-800-782-6761.

**OPERATION**

1. Plug CORD into a grounded electrical outlet of the correct voltage. Electrical shock can occur if appliance is not grounded.
2. Place food products in a pan located directly under the BULB for best results.
3. Adjust FLEXIBLE STEM ASSEMBLY. Do not aim lamp in any direction other than the surface of the table on which the appliance is mounted. Maintain a distance of at least 13" between lamp and surface of table. Always maintain a distance of at least 5" between the hood and any wall.
4. Turn warmer off when not in use.
5. Unplug the warmer before changing BULB. To disconnect warmer, turn switch to off and remove plug from power source.

**CLEANING**

**NOTE:** Proper maintenance plays an important part in the life span and functioning of the warmer.

1. Unplug the warmer before cleaning or changing BULBS.
2. This warmer can be cleaned with a damp sponge and mild soap. Do not immerse in water or other liquid.
3. Follow the cutting board care instructions.

## CARE INSTRUCTIONS FOR WOOD CUTTING BOARD

The average person can lengthen the life of a cutting block five to ten years through observing the following simple rules.

1. Do not allow moisture of any type to stand on the block for long periods of time.
2. Use a good steel scraper or spatula several times a day, as necessary, to keep the cutting surface clean and sanitary. Do not use a steel brush on the cutting surface of your block.
3. Periodically (once every several weeks), depending upon the use, apply an even coat of mineral oil and melted paraffin to the work surface of your cutting block. The liquid paraffin and mineral oil should be mixed together and sponged on with a rag. Allow to dry. The paraffin will set up and then it should be scraped from the work surface.
4. Do not cut fish or fowl on the work surface of your cutting block, unless you have thoroughly followed the instructions in step #3 – as the moisture barrier must be intact prior to cutting any type of fish, seafood, or fowl on the work surface of your cutting block. Always clean the block thoroughly after cutting fish or fowl on the work surface.
5. Be sure never to cut continuously in the same place on the top of your block. Distribute your cutting over the entire work surface so that it will wear evenly.
6. Never wash your cutting block with harsh detergents of any type.
7. At the conclusion of a day's work preparing meat or food on your cutting block, scraping the block will remove 75% of the moisture. After scraping, immediately dry thoroughly with an absorbent towel. This assures an odorless, clean cutting surface for the next day and prevents unnecessary quick deterioration of the work surface.

### 6016-C CARVING STATION BULB WARMER

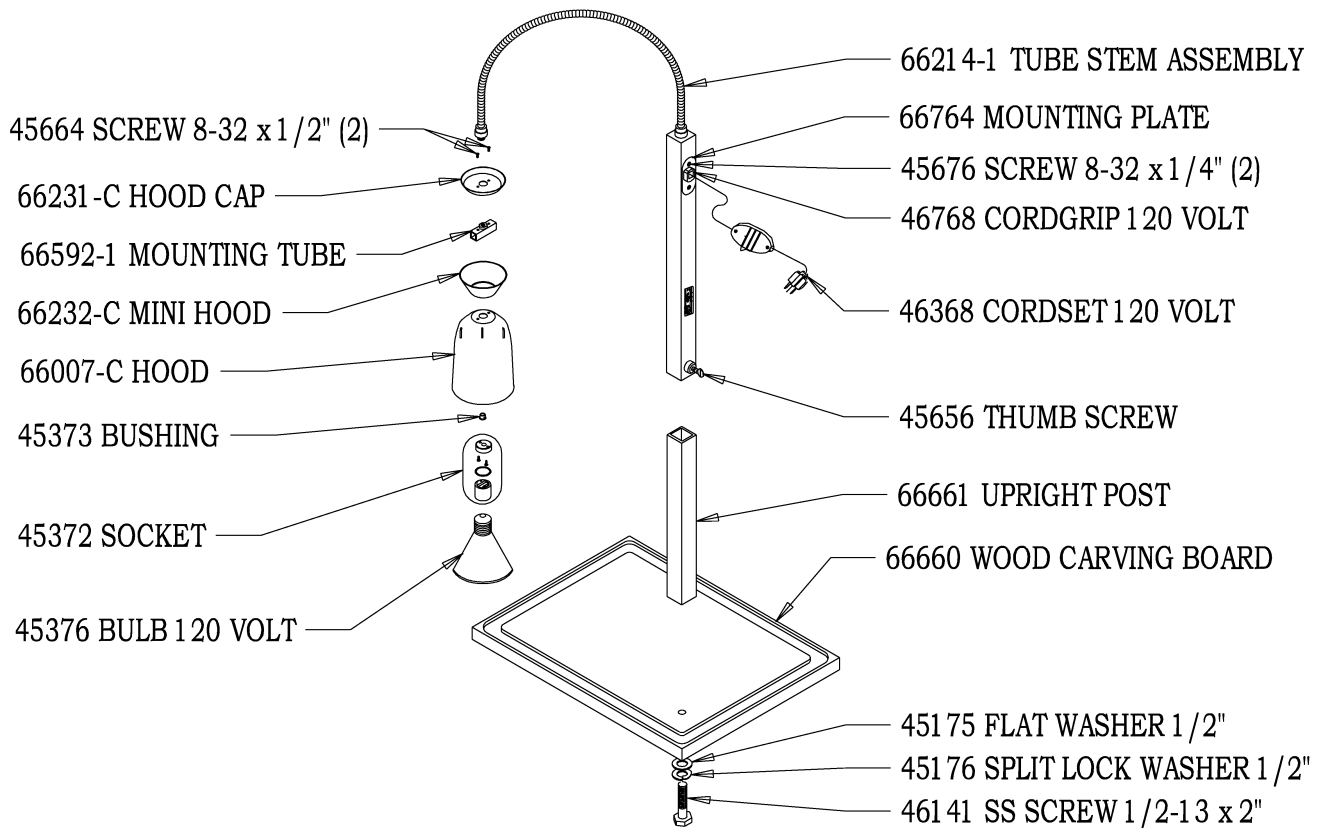

**NEMCO FOOD EQUIPMENT** 301 Meuse Argonne, Hicksville, OH 43526

Phone: (419) 542-7751 Fax: (419) 542-6690 Toll free: 1-800-782-6761

[www.nemcofoodequip.com](http://www.nemcofoodequip.com)

45895  
12/30/03